

CAD FILE :

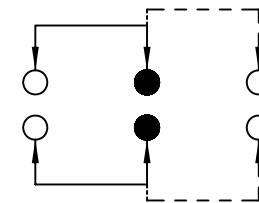

SCHEMATIC (NON-SHORTING)

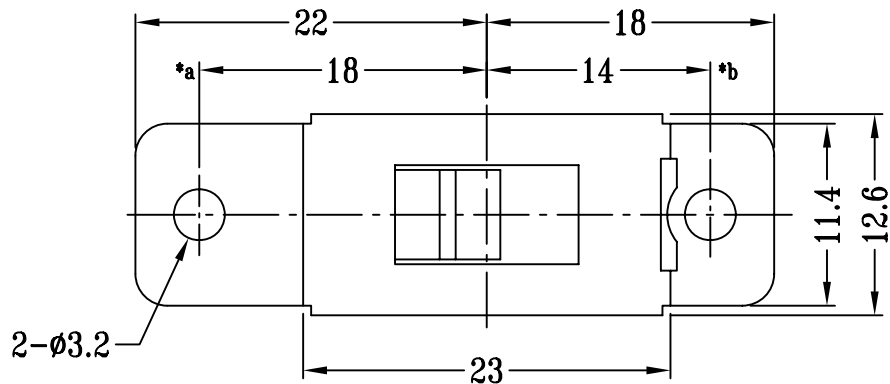
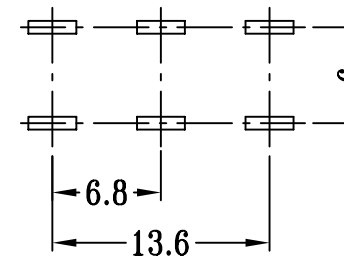
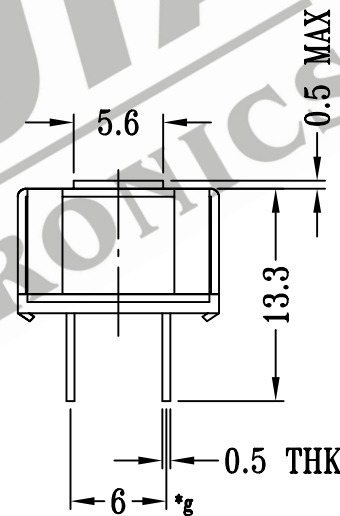
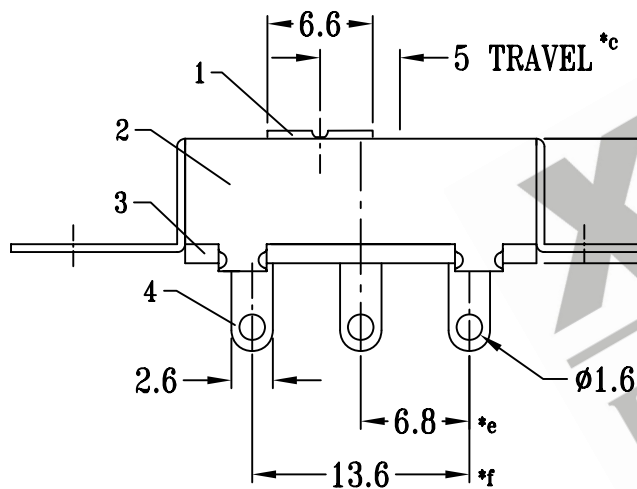

P.C.B. LAYOUT

注:带*表示关键尺寸(7个)

9	SPRING PLATED	PBS STRIP	2	NATURAL
8	CONTACT	COPPER STRIP	2	Ag PLATED
7	POSITION PLATE	STEEL STRIP	1	Ni PLATED
6	STEEL BALL	STEEL	1	NATURAL
5	SPRING	STEEL WIRE	1	TEMPER
4	TERMINAL	BRASS STRIP	6	Ag PLATED OVER Ni PLATED
3	TERMINAL BASE	PHENOLIC RESIN	1	BLACK
2	FRAME	STEEL STRIP	1	BLACK
1	KNOB	PC	1	RED
NO.	PART NAME	MATERIAL	QTY.	FINISHING

TOLERANCE UNLESS SPECIFIED		SHENZHEN XIEJIA ELECTRONICS CO.,LTD.		
WITHIN: 1.5±0.1mm OVER: 1.5±0.2mm		ISSUE	DATE	DESCRIPTIONS
TITLE: VERTICAL SLIDE SWITCH		UNIT : M M	DRWG NO : XJ-DR-SS22K30-00	
MODEL: SS-22K30		SCALE : 2:1	DWN. ZHUMIN	2004-6-22
ALL MATERIALS MUST BE COMPLIANT TO ROHS		APPD. KANGXINAN	FANGYING	2004-6-22
				2004-6-22